

Gas Fan Assisted Sealed Chamber

MODEL		220	300	400	500	800
A	Total height	mm 1600	1950	1766	2036	2146
B	Water header body height	mm 1265	1615	1430	1700	1810
C	Base width	mm 710	710	810	810	1010
D	Water heaters Ø	mm 700	700	800	800	1000
E	Drain 3/4"	mm 480	480	460	460	545
F	Cold water inlet 1" 1/4	mm 645	645	625	625	645
G	Recirculation 1" 1/4	mm 890	950	1026	1026	990
H	Hot water outlet 1" 1/4	mm 1170	1460	1325	1595	1604
I	Fume exhaust axis 60/100	mm 1700	2050	1866	2136	2246
L	gas inlet	mm 630	630	630	630	630

MODEL	Unità	220	300	400	500	800
Capacity of the tank	lt	212	310	410	510	810
Nominal heat input	KW	30	34	34	34	34
Nominal heat output	KW	26,8	30,6	30,6	30,6	30,6
Combustion efficiency	%	92%	93%	93%	93%	94%
Natural gas rate (G20)	m ³ /h	3,17	3,60	3,60	3,60	3,60
LPG gas rate (G30/31)	Kg/h	2,13	2,50	2,50	2,50	2,50
Recovery time (ΔT 25°C)	min.	15	17	23	29	46
Recovery time (ΔT 45°C)	min.	28	31	41	52	82
Single withdraw (ΔT 25°C)	lt	484	660	880	1100	1760
Single withdraw (ΔT 45°C)	lt	268	366	488	611	977
Continuous water output (ΔT 25°C)	lt/h	921	1052	1052	1052	1052
Continuous water output (ΔT 45°C)	lt/h	512	585	585	585	585
Continuous water output (ΔT 30°C)	lt/h	768	877	877	877	877
Electrical data	V-Hz	220-240 V ~ 50 Hz (IP 20)				
Max water pressure	bar	6	6	6	6	6
Empty appliance weight	kg	142	166	177	207	300
Full appliance weight	kg	354	476	587	717	1110

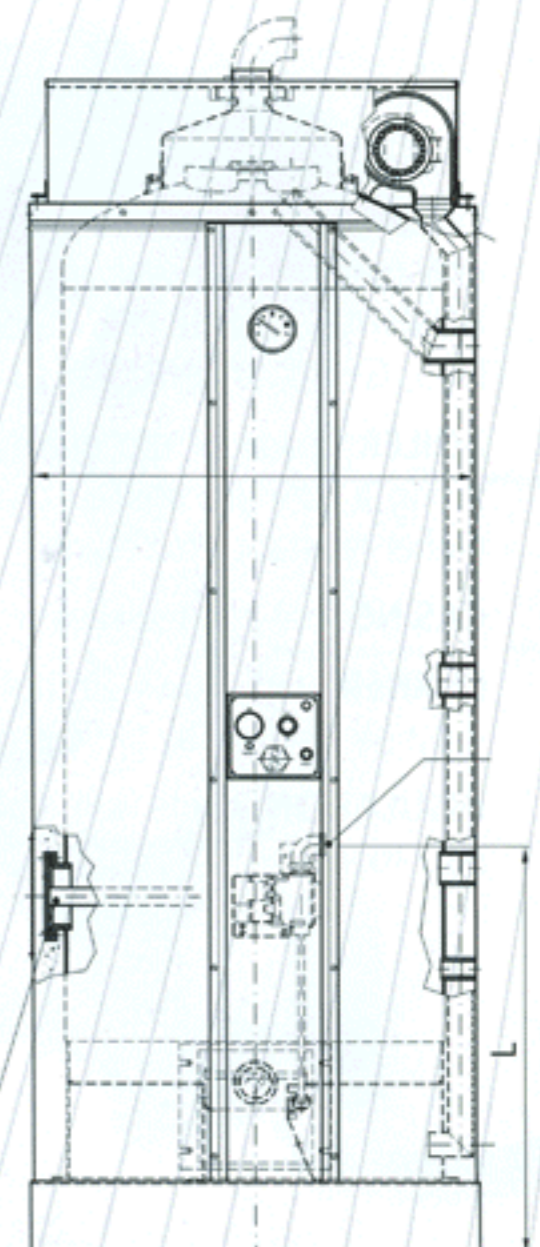
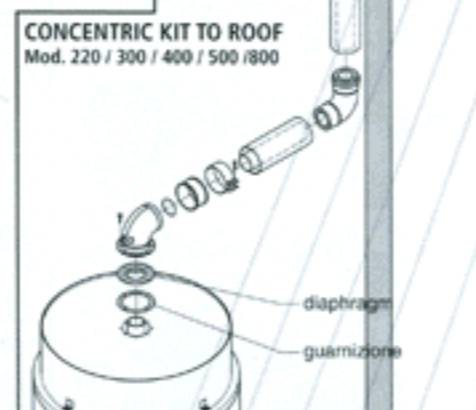
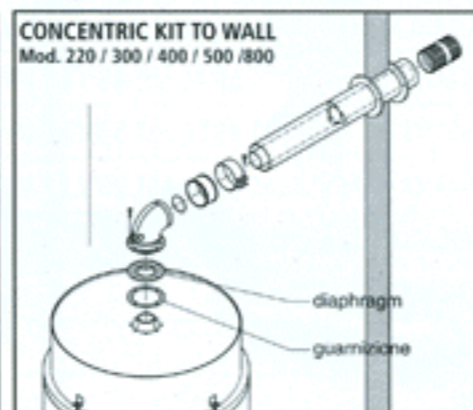
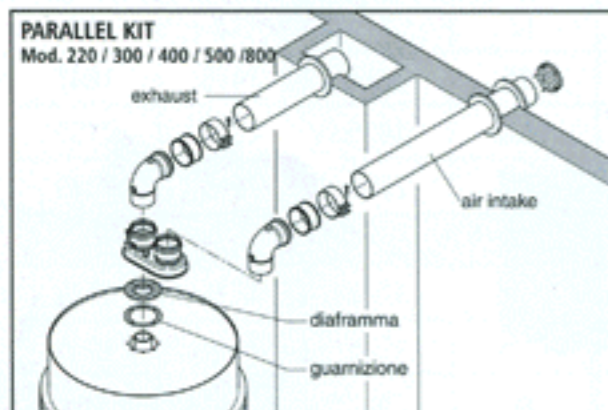

GTF 80 - 120

Gas Fan Assisted Sealed Chamber

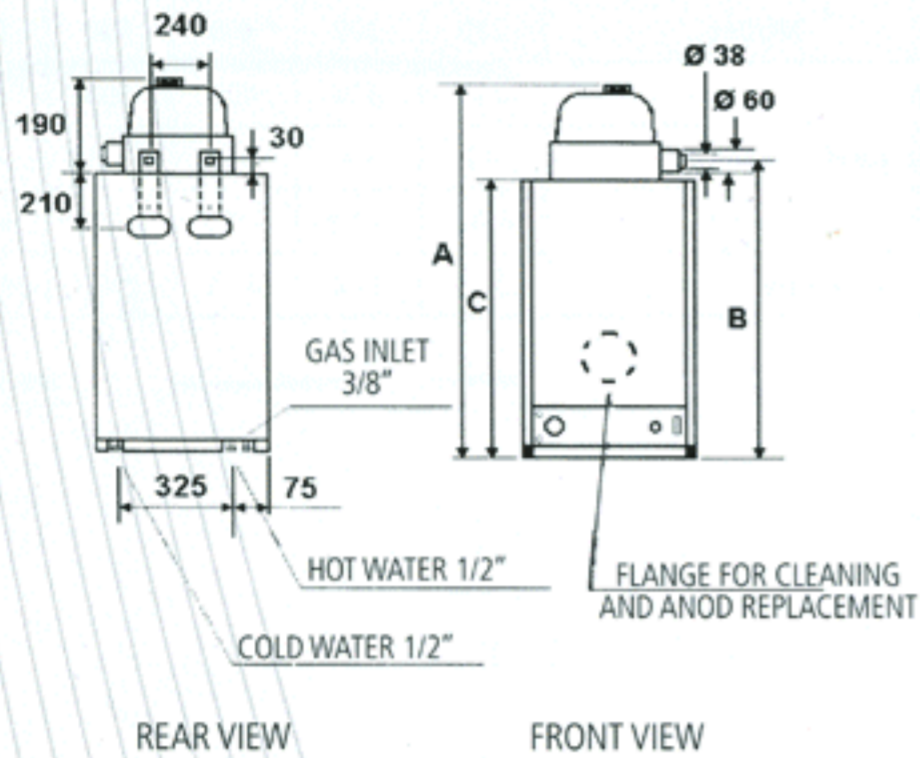

MODEL	80	120
Total height (mm.)	1040	1400
Exhaust height	895	1255
Inner diameter exhaust pipe (mm.)	38	38
Inner diameter air intake pipe (mm.)	60	60
Diameter flange for inspection and anod replacement (mm.)	85	85

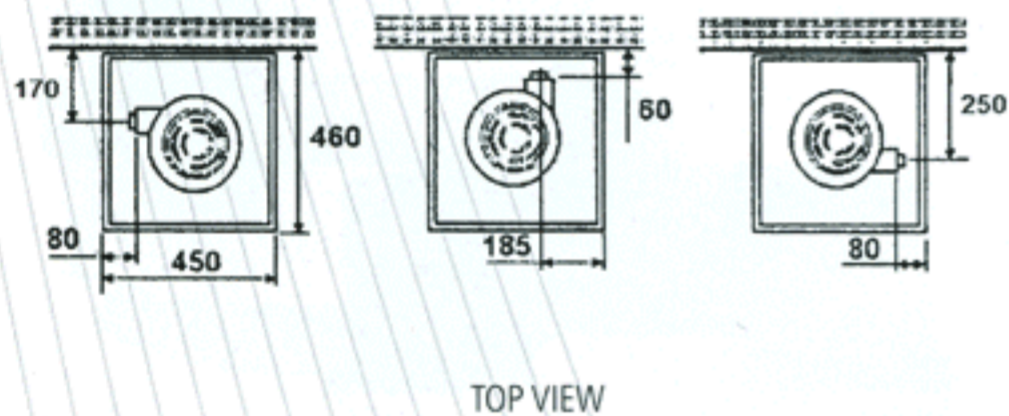

MODEL	Unit	80	120
Capacity	lt	75	115
Nominal Heat input	Kcal/h	4300	4300
	K/W	5,0	5,0
Nominal heat output	Kcal/h	4040	4040
	K/W	4,7	4,7
Combustion efficiency	%	94%	94%
Single spillage at 40°C (termost. 70°C - inlet temp. 15°C)	lt	147	231
First 10 min. spillage at 40°C (termost. 70°C - inlet temp. 15°C)	lt	168	252
Recovery time at 40°C (inlet temp. 15°C)	min.	25	38
Continuous water output at 40°C (inlet temp. 15°C)	lt/h.	164	164
Supply	volt	220-240	220-240
Frequency	hz	50	50
Electrical power	w	26	26
Max water pressure	bar	6	6
Empty weight	Kg	49	49

HORIZONTAL KIT Mod. 80 / 120

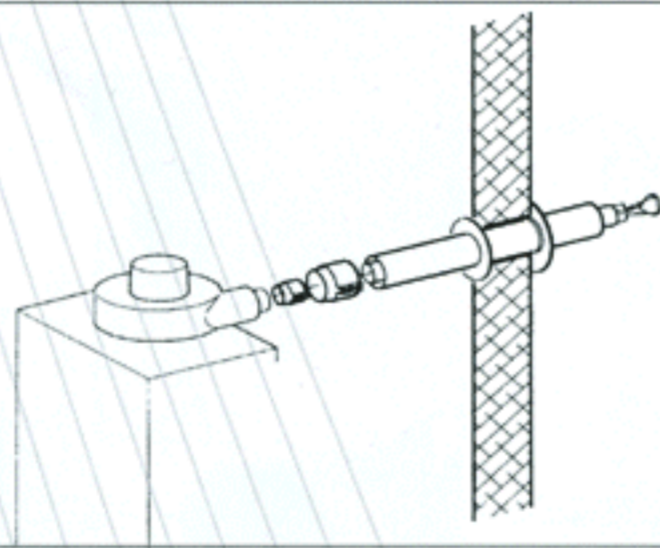

VERTICAL KIT Mod. 80 / 120

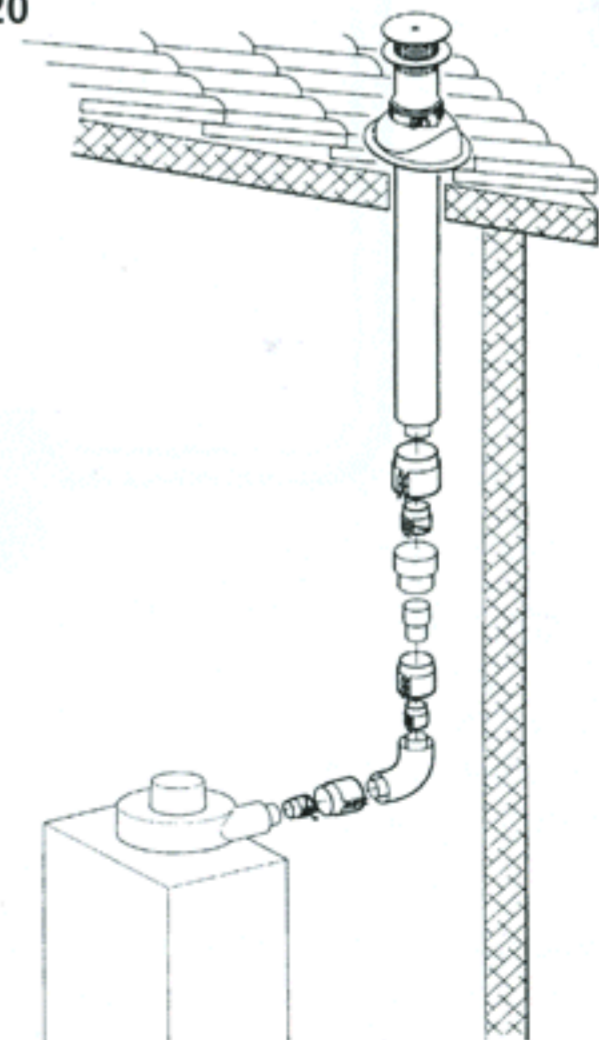

PARALLEL KIT Mod. 80 / 120

