

SPECIFICATION



Standard Features :

- Batch capacity 60kg
- 900 RPM extract force
- All parts in contact with wash solution are made of stainless steel
- PLC control with text and graphic display
- Stainless steel cabinets
- 0-99 adjustable pressure programs
- Variable frequency drive
- Heavy duty frame
- Heavy duty suspension system
- Maximum rotational speed: 1000 RPM
- Unloading tilt
- Smooth and balanced operation
- High performance centrifugal extractor

Optional Features :

- Batch capacity up to 70kg
- Water Pump



MODEL			CTF-60
Units of Measurement	Metric	US	
Maximum Capacity	kg	lbs	60(132.27)
Loading capacity for dry weight linen:			
Hourly capacity	Kg/hr		540
Cycle time depending on the kind of linen:	min		5
Extraction time at rotational speed at 5 min. – cycle (max.)	Second		120
Batches per hour (max.)	Piece		9
Overall Dimensions :			
A - Machine Width	mm.	inch	2290 (90.15")
B - Machine Depth	mm.	inch	3293 (129.64")
C - Machine Height	mm.	inch	2301 (90.59")
D - Machine Height at full	mm.	inch	3515 (138.38")
Cylinder Information :			
Basket of inner Diameter	mm.	inch	1087 (42.79")
Basket of outer Diameter	mm.	inch	1095 (43.11")
Basket Depth	mm.	inch	830 (32.67")
Basket of loading opening	mm.	inch	857 (33.74")
Basket Volume	cu.m	cu.ft	0.8 (28.2)
Drive Information :			
Number of Motors	Number		1
Main Drive Motor	kW	HP	18.5 (25)
Number of Motors	Number		1
Main Drive Motor Conveyor	kW	HP	0.37 (0.4)
Rotational speed:			
Speed	RPM	G-Force	900 (500)
Drain Outlets :			
Number of Drains	Number		1
Drain Size	mm.	inch	152.4 (6")
Compressed Air System :			
Air Inlet Connection	mm.	inch	12 (1/2")
Air Pressure	bar	psi	6-8 (87-116)
Unloading Conveyor:			
Belt width	mm.	inch	1000 (39.37)
Weight and Shipping Information :			
Net Weight (approx.)	kg.	lbs.	5100 (11243.6)
Domestic Shipping weight (approx.)	kg.	lbs.	5200 (11464)

Specification of design is subject to change without notice. For additional options please consult factory and distributor.

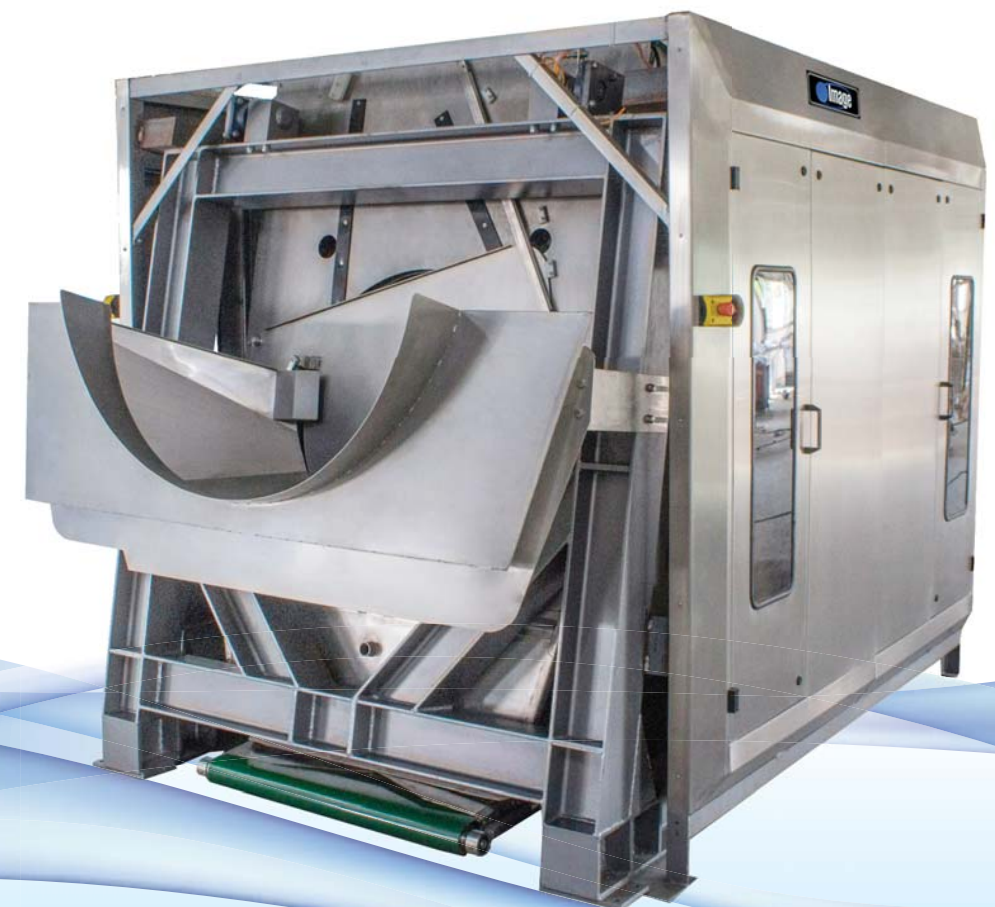
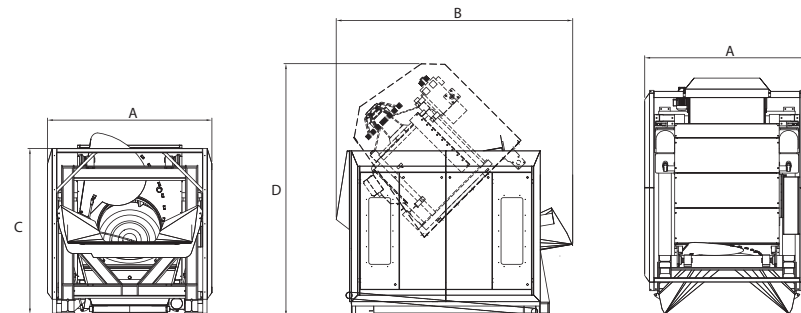

Centrifugal Extractor

CTF Series
MODEL : CTF-60





CTF Series - Centrifugal

CTF Series - The IMAGE centrifugal extractor is intended for use behind continuous batch washing machines, and is integrated in the work flow of the washing line directly behind the washing machine.

The machine operates in the same rhythm as the washing machine and requires no operating staff. The water is extracted from the batch-lot linen and is ejected as a loose heap of linen.

Swivel Frame

The swivel frame is suspended in bearings in the upper transverse bar of the base frame. The swivel frame contains the drum unit suspended on springs. For unloading the linen, two pneumatic cylinders lift the swivel frame so that the drum opening points down at an angle of approx. 45°

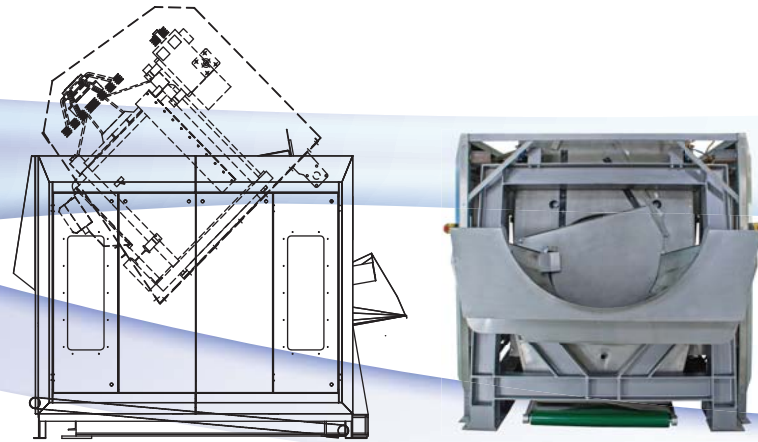

Robust Energy Efficient Drive

The machine is provided with a single totally enclosed standard motor that is controlled electronically by a variable frequency drive. This makes the machine control simple and very flexible. The inverter reduces the peak energy demands, saving energy, and lowers the inrush current. It is also a watchdog for the motor, protecting against overload and over voltage. The single motor drive and inverter eliminate clutches, gear reducers, and idlers, plus reduces the use of electromechanical components such as contactors and relays. It provides a powerful yet simple drive alternative that is more economical than multi-motor drives. The inverter makes it possible to achieve high extract speeds and significantly save energy and time in the drying process. A multi-motor drive is optional.



Powerful Control System

Easy to understand control and programming software make it simple to adjust the machine for every extract process and all program parameter. The user terminal has a touch screen monitor for visualizing all necessary information in graphic mode from the high quality PLC system. Pending angle and turning speed can be programmed.



Unloading Conveyor

The linen is unloaded on an unloading belt integrated in the base frame, below the swivel frame. Lateral walls are made of stainless steel to prevent the linen falling off. By means of a pneumatic cylinder, the walls open automatically, when the swivel frame is moved upwards.



Drum Unit

The outside drum encloses the rotating inside drum. Both components are made of stainless steel. The bearing of the inside drum is attached to the outside drum. The outside drum also contains the drive motor, which drives the inside drum by means of a V – belt system. The drum mantle of the inside drum is perforated, and the inflatable unloading components (hoses) are equally distributed along the circumference. The inflatable hoses are enclosed by a protective polyester tissue. During the unloading process the hoses are inflated by pulsating compressed air, and thus detach the linen from the inside drum.

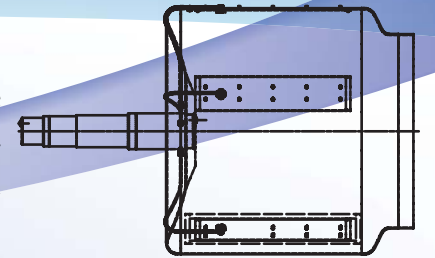

Drive and Bearing

A three – phase asynchronous motor is used for drive. The drive is addressed by a frequency converter. The speed and the sense of rotation (especially during the loading and unloading phase) can thus be set freely and can be adapted to any type of linen. The drive motor drives the inside drum by means of a V – belt system. The bearing system of the inside drum consists primarily of a cylindrical roller bearing and a spherical roller bearing. Two radial shaft packing are attached to provide sealing towards the water side.

